

UBS 2424-1SH

UNIVERSAL BROADBAND

Advancing Technologies for Broadband Service Providers • The UTStarcom Universal Broadband Server (UBS) is an environmentally hardened, fully sealed, line-powered DSL access multiplexor (DSLAM) that provides up to 4.6Mbps DSL service using G.SHDSL standards. The UBS provides the critical features and carrier class reliability require Service Providers in order to offer ADSL and other high bandwidth services to customers who are currently served from Digital Loop Carriers (DLCs) or are located further than 12,000 feet (3.7 km) from a Central Office (CO).



- **24 PORTS STANDARDS COMPLIANT ADSL WITH INTEGRATED POTS SPLITTERS**
- **LINE-POWERED – REQUIRES NO ADDITIONAL REMOTE POWER INFRASTRUCTURE AND REDUCES POTENTIAL FOR LOSS OF SERVICE**
- **MULTIPLE DEPLOYMENT OPTIONS—UNDERGROUND POLE-MOUNTED, OR PEDESTAL**
- **2 OR 4 WIRE G.SHDSL STANDARD COMPLIANT BACKHAUL**
- **REMOTELY PROVISIONED AND MANAGED THROUGH CLI, TELNET, OR SNMP,**
- **HERMETICALLY SEALED AND ENVIRONMENTALLY HARDENED FOR DEPLOYMENT ANYWHERE**

TECHNOLOGY ENABLERS

The UBS from UTStarcom is a self-contained, line-powered DSL access multiplexor (DSLAM) which allow service providers to overcome current technical and economic barriers to universal profitable broadband deployment. For the first time, service providers can now cost-effectively reach subscribers beyond 20,000 feet (6km) with full ADSL services.

Each UBS contains 24 standards-compliant ADSL modems to provide high speed service to subscribers. Traffic from all 24 subscribers is aggregated within the UBS and backhauled to the service provider’s ATM network using either 2 or 4 wire G.SHDSL standards.

Because it is line-powered, the UBS does not possess the same inherent physical restrictions associated with other costlier remote DSLAMs and mini-RAMs. While remote DSLAMs and mini-RAMs require expensive local power and battery backup in the CO or Remote Terminal (RT) cabinet, the UBS receives power using Express Power, enabling it to be located anywhere in the network — even in the passive cross-connect cabinets at the Serving Area Interface (SAI).

Since the UBS is fully sealed and environmentally hardened, service providers can deploy it in unlimited applications: in or on unconditioned cabinets or pedestals, mounted on poles, or buried underground. The product can even be submerged in water for flooded man hole or hand hole applications.

MANAGEMENT

The system can be managed via anywhere in the network using an in-band management channel (PVC) within the backhaul circuit. The UBS supports SNMP, TL1 and Command line (CLI) management interfaces.to simplify he integration with existing carrier Operational Support Systems (OSSs).

LINE POWER

The UBS is powered from seperate express power pair. this allows the carrier to provide line powering to the system. The UBS supports up to 8 power inputs which are powered using Express Power Modules located at the Central office.

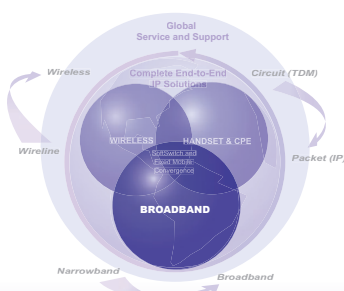

Technical Specifications

PHYSICAL

Dimensions: 18.9"x14.25"x5" (48cmx36.2cmx12.7cm)
Weight: 40 lbs (18kg)
MTBF: >15 years

ENVIRONMENT

Operating Temperature: -40C to +75C (-40F to +167F)
Humidity: 0% to 100%
Altitude: No restrictions

POWER

- 175 VDC Line power per ANSIT1.418 and EN 60950

POTS/ADSL CABLING

- 20'(6m) cable or Integrated splice case options
- 50 pair CUPIC double-armor
- Pre-terminated w/3M 4005-DPM/TR supermate modules (MS2)

ADSL PORT SPECIFICATIONS

- ADSL Port Specifications
- 24 ATU-C ports per UBS
- ADSL asymmetrical maximum rates
 - 8 Mbps downstream, 1 Mbps upstream
- Modulation Supported
 - G.992.1 (full rate DMT)
 - G.992.2 (G.Lite)
 - ANSIT1.413

NETWORK INTERFACES

- G.shdsl per ITU-T G.991.2 (Annex A and B):
 - 2.3 Mbps symmetric using 1 pair
 - 4.6 Mbps symmetric using 2 pairs
 - Symmetric 72 Kbps to 4.6 Mbps on 64 Kbps increments
 - Supports repeaters
- Software Selectable for Annex A or B
- Software Selectable for 2 wire or 4 wire

LINE SHARING

- Simultaneous POTS and ADSL per ANSIT1.413

ATM QUALITY OF SERVICE

- Service categories:
UBR, UBR+, VBR-rt, VBR-nrt, CBR
- Traffic Management functions:
CAC, UPC, Traffic Shaping, Cell Tagging, Selective Cell discarding
Frame discard

REGULATORY AND SAFETY APPROVALS

- NEBS Level 3 (GR-63-CORE + GR-1089-CORE)
- FCC Part 15 Class A
- GR-487-CORE (as applicable)
- GR-950-CORE (as applicable)

NETWORK MANAGEMENT

- SNMP, TL1 and CLI
- UBSView - EMS providing full management capability

STANDARDS BASED G.SHDSL 2 OR 4 WIRE TRANSPORT

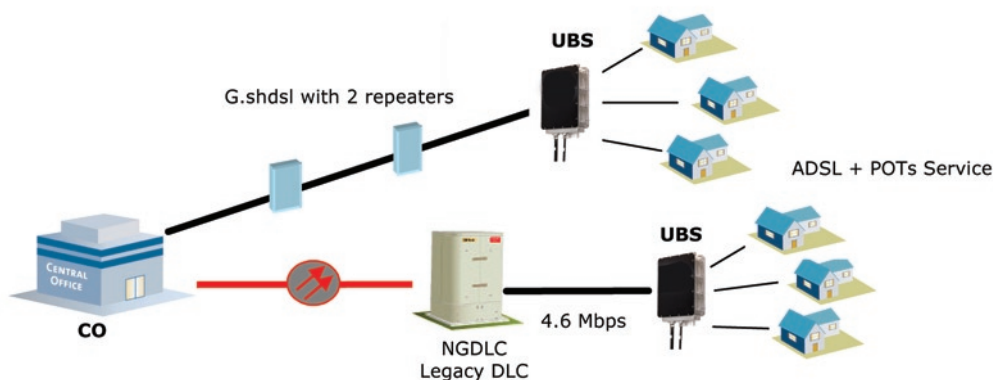

Please note the information contained herein is for informational purposes only. Technical claims listed depend on a series of technical assumptions. Your experience with these products may differ if you operate the products in an environment, which is different from the technical assumptions. UTStarcom reserves the right to modify these specifications without prior notice. UTStarcom makes no warranties, express or implied, on the information contained in this document.

UTStarcom, Inc. USA
1275 Harbor Bay Parkway
Alameda, CA 94502 USA
Tel: 510-864-8800
Fax: 510-864-8802

www.utstar.com

About UTStarcom, Inc.

UTStarcom is a global leader in IP-based, end-to-end networking solutions and international service and support. The company sells its broadband, wireless, and handset solutions to operators in both emerging and established telecommunications markets around the world. UTStarcom enables its customers to rapidly deploy revenue-generating access services using their existing infrastructure, while providing a migration path to cost-efficient, end-to-end IP networks. Founded in 1991 and headquartered in Alameda, California, the company has research and design operations in the United States, China, Korea and India. UTStarcom is a FORTUNE 1000 company. For more information about UTStarcom, visit the company's Web site at www.utstar.com

Copyright © 2006 UTStarcom, Inc. All Rights Reserved. UTStarcom is a registered trademark, the UTStarcom logo and A World of Better Communication are trademarks of UTStarcom, Inc. and its subsidiaries.