

UBS 4848-4H

UNIVERSAL BROADBAND SERVER

Advancing Technologies for Broadband Service Providers • The UTStarcom Universal Broadband Server (UBS) is an environmentally hardened, fully sealed, line-powered DSL access multiplexors (DSLAM) that provides up to 6Mbps DSL service. The UBS provides the critical features and carrier class reliability require service providers in order to offer ADSL and other ultra-broadband services to customers who are currently served from Digital Loop Carriers (DLCs) or are located further than 12,000 feet from a Central Office (CO).



- **48 PORTS STANDARDS COMPLIANT ADSL WITH INTEGRATED POTS SPLITTERS**
- **LOCAL AND LINE POWERED OPTIONS TO MAXIMIZE USE OF EXISTING POWER INFRASTRUCTURE**
- **DEPLOYABLE ANYWHERE UNDERGROUND, POLE MOUNTED, OR PEDESTAL**
- **T1-IMA OR T1-UNI BACKHAUL OVER STANDARDS-COMPLIANT HDSL2 OR HDSL4**
- **REMOTELY PROVISIONED AND MANAGED THROUGH CLI, TELNET, OR SNMP**
- **EASY TO INSTALL AND MAINTAIN TO PROVIDE RAPID, RELIABLE DSL SERVICE DELIVERY**
- **HERMETICALLY SEALED AND ENVIRONMENTALLY HARDENED TO SUPPORT DEPLOYMENT IN ANY ENVIRONMENT**

TECHNOLOGY ENABLERS

The UBS from UTStarcom is a self-contained, line-powered DSL access multiplexor (DSLAM) which allows service providers to overcome current technical and economic barriers to universal profitable broadband deployment. For the first time, service providers can now cost-effectively reach subscribers beyond 80,000 feet with full 6Mbps ADSL services.

Each UBS 4848-4H contains 48 standards-compliant ADSL modems to provide high speed service to subscribers. Traffic from all 48 subscribers is aggregated within the UBS and backhauled to the service provider's ATM network using either T1- UNI or T1- IMA technology over one or more HDSL2 or HDSL4 uplink circuits.

Because the UBS can be line-powered, it does not require expensive local power and battery backup in the Remote Terminal (RT) cabinet, unlike other solutions such as mini-RAMs or remote DSLAMs. This enables the UBS to be located anywhere in the network — even in the passive crossconnect cabinets at the Serving Area Interface (SAI). The UBS is unique in that it can receive line power through either the backhaul connection, or through separate express power pairs. This allows the UBS to use the fewest pair of any line powered DSLAM.

INSTALLATION

The UBS was designed with outside plant in mind and is very easy to install. Since the UBS is watertight and environmentally hardened, service providers can deploy it anywhere: in or on unconditioned cabinets or pedestals, mounted on poles, or buried underground. The product can even be submerged in water for flooded man hole or hand hole deployments. The fully standards-compliant UBS is interoperable with all industry standard equipment, including any standard-compliant ADSL CPE and any HDSL2 or HDSL4 (backhaul) transport system. This allows the UBS to be deployed in conjunction with the existing network equipment, enabling a carrier to leverage its existing infrastructure.

MANAGEMENT

The system can be managed from anywhere in the network using an inband management channel within the backhaul circuit. Using this inband channel a carrier can fully configure and provision a UBS remotely from its CO or NOC center. The UBS supports standards-based SNMP, T11 and CLI management interfaces to simplify integration with existing carrier operational support systems (OSS).

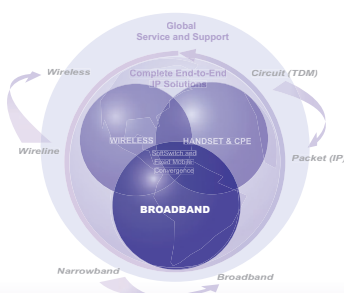

PHYSICAL

Dimensions: 18.9"x14.25"x5"
Weight: 48 lbs

ENVIRONMENT

Operating Temperature: -40C to +75C (-40F to +167F)
Humidity: 0% to 100%
Altitude: No restrictions

POWER

- 175 VDC Line power per ANSIT1.418 and EN 60950
- 48 VDC option

POTS/ADSL CABLING

- 20' cable or Integrated splice case options
- 100 pair CUPIC double-armor
- Pre-terminated w/3M 4005-DPM/TR supermate modules (MS2)

HDSL2/HDSL4 AND EXPRESS POWER CABLING

- 25 pair CUPIC double-armor
- Pre-terminated w/3M 4005-DPM/TR supermate modules (MS2)

ADSL PORT SPECIFICATIONS

- 48ATU-C ports per UBS
- ADSL asymmetrical maximum rates
8 Mbps downstream, 1 Mbps upstream
- Modulation Supported
G.992.1 (full rate DMT)
G.992.2 (G.Lite)
ANSIT1.413

STANDARDS BASED HDSL2 OR HDSL4 TRANSPORT

NETWORK INTERFACES

- Software Selectable for T1 IMA or T1 UNI
- Software Selectable for HDSL2 or HDSL4 interfaces

LINE SHARING

- Simultaneous POTS and ADSL per ANSIT1.413
- Pairs sharing both data and power per HDSL2 and HDSL4 standards

ATM QUALITY OF SERVICE

- Service categories:
UBR, UBR+, VBR-rt, VBR-nrt, CBR
- Traffic Management functions:
CAC, UPC, Traffic Shaping, Cell Tagging, Selective Cell discarding, Frame discard, Oversubscription

REGULATORY AND SAFETY APPROVALS

- NEBS Level 3 (GR-63-CORE + GR-1089-CORE)
- FCC Part 15 Class A
- GR-487-CORE
- GR-950-CORE (as applicable)

NETWORK MANAGEMENT

- SNMP, MIBII, ADSL MIBs per RFC 2662, HDSL MIBs per RFC 3276, ATM MIBs per RFC 2515
- CLI- Help driven Command Line Interface
- Support for full FCAPS functionality

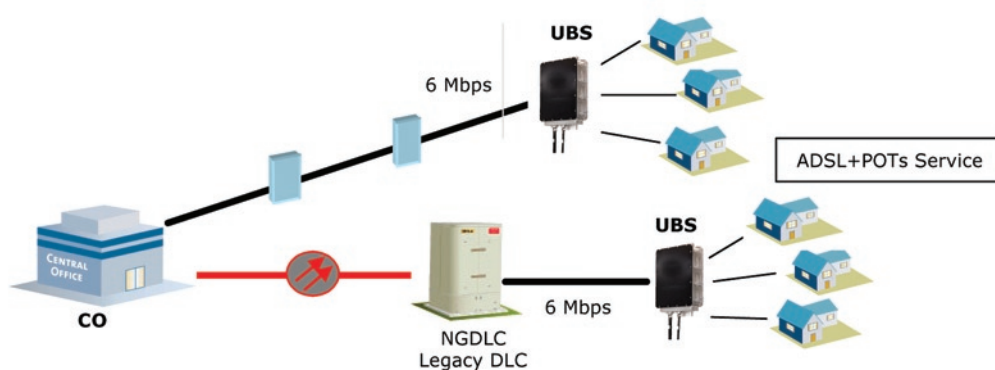

Please note the information contained herein is for informational purposes only. Technical claims listed depend on a series of technical assumptions. Your experience with these products may differ if you operate the products in an environment, which is different from the technical assumptions. UTStarcom reserves the right to modify these specifications without prior notice. UTStarcom makes no warranties, express or implied, on the information contained in this document.

UTStarcom, Inc. USA
1275 Harbor Bay Parkway
Alameda, CA 94502 USA
Tel: 510-864-8800
Fax: 510-864-8802

www.utstar.com

About UTStarcom, Inc.

UTStarcom is a global leader in IP-based, end-to-end networking solutions and international service and support. The company sells its broadband, wireless, and handset solutions to operators in both emerging and established telecommunications markets around the world. UTStarcom enables its customers to rapidly deploy revenue-generating access services using their existing infrastructure, while providing a migration path to cost-efficient, end-to-end IP networks. Founded in 1991 and headquartered in Alameda, California, the company has research and design operations in the United States, China, Korea and India. UTStarcom is a FORTUNE 1000 company. For more information about UTStarcom, visit the company's Web site at www.utstar.com

Copyright © 2006 UTStarcom, Inc. All Rights Reserved. UTStarcom is a registered trademark, and the UTStarcom logo and A World of Better Communication are trademarks of UTStarcom, Inc. and its subsidiaries.